



Electric Chain Hoist

Single
Phase



New design

Innovation

Compact

Efficiency

Global No.1

**Permanently Magnetic
Brushless Hoist Motor**

Powerful • Energy economical • Safety

Low speed with stepless control
0 ~ 3.2 (m/min)



MODEL:BLFD



▲ Hoist packed in convenient molded carrying case with built-in handle.

Features of Handy Lifter :

- (1) Available in single Phase
(110V ,220V ,115V ,230V) ± 10% 60Hz/50Hz
- (2) Standard IP54, motor with insulation F and over heat protection.
- (3) Variable frequency control, low starting current, high efficiency.
- (4) Standard 2 speed control, with infinitely variable low speed using adjustable knob on push button.
- (5) Adjustable friction clutch serving as overload limit will slip while overload.
- (6) Upper/lower limit switch prevent over-wind; Emergency stop will switch off power immediately in an emergency condition.
- (7) Light weight design and easy to carry. Hoist weight only 16-17kgs, but can lift up to 240kgs or 480kgs in 2-fall.
- (8) Unit comes in its own carrying case.
- (9) Other option upon on request.

Dimensions

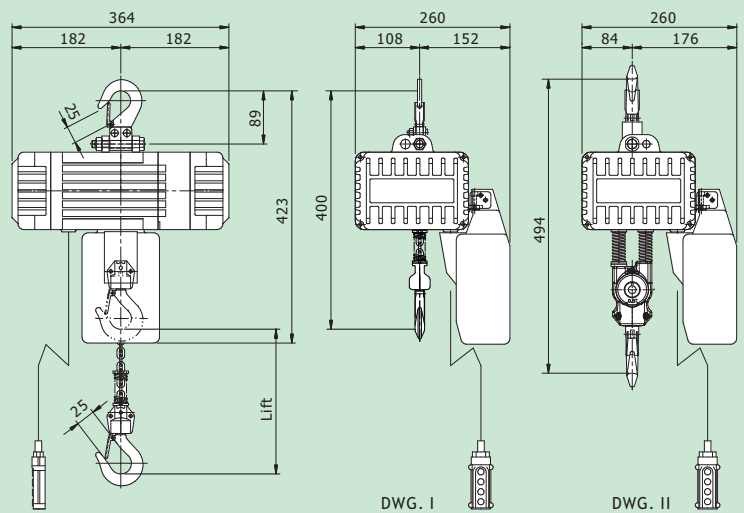

Specifications:

Rated Power Source		Single Phase (110V ,220V ,115V ,230V) ± 10% 60Hz/50Hz													
Model (Dual-Speed-Type)	DWG.	Rated Load (kg)	Motor Output (w)	Time Rating (min)	Intermittent Duty		Rated Current (A)	Lifting Speed (m/min)		Standard Lift (m)	Push Button Cord (m)	Load Chain Diameter (mm)	Fall No.	N.W./G.W. (kg)	
					ED%	Max. Starting Frequency (times/hr)		110V	220V					3m	6m
BLFD-008	I	80	300	15	30	180	6.0(110V)	0-4.8/18	0-4.8/18	3	3	4X12	1	16.5/	17.5/
BLFD-012	I	120					3.0(220V)	0-3.2/12.5	0-3.2/12.5						
BLFD-016	I	160	600	15	30	180	10.0(110V)	0-4.8/18	0-4.8/18	3	3	4X12	1	16.5/	17.5/
BLFD-024	I	240					5.0(220V)	0-3.2/11.2	0-3.2/12.5						
BLFD-032	II	320	600	15	30	180	10.0(110V)	0-2.4/9	0-2.4/9	3	3	4X12	2	19.4/	21.5/
BLFD-048	II	480					5.0(220V)	0-1.6/5.6	0-1.6/6.3						

Packing (L x W x H) : 500 x 390 x 205 (mm) ※ Maximum Push Button Cable Length 20m

Chain Bucket No. Selection Table

Model	Rated Load	Fall No.	Chain (mm)	Lift(m)																								Bucket No.	Bucket size(mm) LxWxH
				3	4	5	6	7	8	9	10	11	12	13	14	15	16	17	18	19	20	21	22	23	24				
BLFD-008	80kg	1	§ 4X12	BD1#				BD2#				BD3#				BD4#				BD1#	90X130X245								
BLFD-012	120kg	1		BD1#				BD2#				BD3#				BD4#				BD2#	120X160X230								
BLFD-016	160kg	1		BD1#				BD2#				BD3#				BD4#				BD3#	130X170X260								
BLFD-024	240kg	1		BD1#				BD2#				BD3#				BD4#				BD4#	130X170X310								
BLFD-032	320kg	2		BD1#				BD2#				BD3#				BD4#													
BLFD-048	480kg	2		BD1#				BD2#				BD3#				BD4#													



CHENG DAY MACHINERY WORKS CO., LTD.

No. 173, Wen Chiu Rd., Dajia Dist., Taichung City 437, Taiwan (R.O.C)
 Tel: +886-4-2688-1581 Fax: +886-4-2688-1509
 Website: www.chengday.com.tw E-mail: info@chengday.com.tw

- Revision of February, 2013 (Edition No.7) #950158
- No further notice while sizes and dimensions update ; Quotations are based on practical dimensions.
- Due to the printing factors, the color of the products is subject to minor deviation from the physical objects.